

NX 300 | NX 300h



“We’ve made the NX bolder, sleeker and more distinctive. Not stopping there, my team improved its ride comfort before adding some of the world’s most advanced automotive technologies, including the latest Lexus Safety System +.”

NX CHIEF ENGINEER
TAKEAKI KATO



06
DESIGN

Being bold – a crossover whose radical design turns heads

08
'OMOTENASHI'

A car that seamlessly anticipates your needs

12
PERFORMANCE

How a passion for performance led to exceptional urban agility

16
CRAFTSMANSHIP

Where street design meets 'Takumi' craftsmanship

20
TECHNOLOGY

Applying advanced technologies to put the pleasure back into city driving

22
SELECT

In this brochure we invite you to prepare for the excitement of choosing your Lexus NX

58
THE LEXUS EXPERIENCE

Learn how we aim to treat every customer as if they were a guest in our own home

Welcome to the Lexus NX crossover. Radical and challenging in appearance, it has been designed for people who want to stand out in the city. From its bold Lexus signature grille and LED headlights to its unique roofline and sculpted profile, the NX is alive with imaginative design ideas. Available as the pioneering NX 300h Self-Charging Hybrid or dynamic NX 300 petrol turbo, it delivers impressive urban agility thanks to an advanced suspension system that responds fluently to your demands.

You'll travel in a cockpit of great refinement, featuring a 10.3-inch Lexus Premium Navigation display, while enjoying the stylish look and feel of beautiful leather stitching and exquisite detailing. For an even more dynamic experience, you can choose the NX F SPORT with its exclusive F-mesh grille, more responsive suspension, F SPORT interior and distinctive new wheels. Important for your peace of mind, the NX is available with Lexus Safety System + that can now detect pedestrians at night and cyclists during daytime.





NX 300



"We want design that thrills, design that excites and is controversial. We want cars with attitude that turn heads."

PROJECT GENERAL MANAGER
FOR THE LF-NX CROSSOVER CONCEPT
TAKESHI TANABE

THE LEXUS NX: THE ART OF STANDING OUT

The creation of the NX was an exceptional opportunity for Lexus to reach out to a new generation of car buyers who are looking for stand-out originality and design excitement. It was not a time for conservatism or timidity. Not a time for 'me-too' designs or ideas that had been watered down by too many focus groups and committee meetings. It was a time for boldness.

We gathered together the brightest young guns from our design studios in California, the South of France and Japan. We gave them a blank sheet of paper, offered them a new level of creative freedom and urged them to be daring. Inspired by the unprecedented openness of this brief, they produced five highly creative concepts.

And then we selected the most radical and challenging proposal of them all for further development. In essence, the winning concept had a diamond-shaped cabin that was formed around the space needed for its four occupants, with wheels located at each of the four facets of a gemstone.

The look was sporty and agile, yet at the same time decidedly edgy and urban.

In the words of its designer, Nobuyuki Tomatsu: "We wanted this car to be lean and rough in a cool contemporary way. When you look at it in profile, it's like a featherweight boxer. We cut away every ounce of fat from the cabin sides to give it a muscular and sculpted form."

Wherever you look, the NX is full of exciting new design ideas: the diamond shape when seen from above; the muscular bumpers at front and rear; and the unique roof treatment which peaks above the heads of the rear occupants then slopes down abruptly to the rear, giving the car its highly distinctive profile. The front lights have a uniquely futuristic look and the famous Lexus signature grille has never appeared so dynamic on the NX.

The test was to turn these ideas into reality without blunting their cutting edge. Our priority was to retain the concept's sense of condensed strength

and muscularity, which is expressed in the very folds of the metal. Usually when challenging lines meet production constraints it is the design that has to be changed, not the production process. But the NX was such a thrilling vehicle that it inspired us all to take a very different approach. Here's Kenji Chiba, head of our Body Design Division: "The design was cool. I understood it would be demanding technologically, but I felt a sense of duty that I had to somehow realise it. If we don't make something cool instead of just what is easy to manufacture, then we have no future."

As a result of such determination, the NX is one of the most radical designs on the road today. And we're delighted to say that it's attracting a whole new generation of fans to the Lexus brand. In fact, the NX is one of the most successful new launches in our history. Which just confirms our view that bravery and boldness bring their own rewards.

DESIGN



01



02

01 Lexus signature grille with exclusive F-mesh pattern
02 Triple LED headlights



Seated in figure-hugging seats, you and your passengers will discover exquisite craftsmanship like the traditional Naguri-style aluminium inlay available on the NX F SPORT. The word 'Naguri' stems from a traditional Japanese wood-shaving technique. The process had been forgotten for centuries, until one of our suppliers developed a new way of crafting aluminium to create a traditional Naguri finish, and our designers were immediately excited by the creative possibilities.

'OMOTENASHI': SEAMLESSLY ANTICIPATING YOUR NEEDS

'Omotenashi' is a time-honoured Japanese concept that's all about anticipating the needs of people, even before they arise. It raises hospitality almost to an art form, as in the famous tea ceremony, where every guest is treated with warmth, understanding and respect. Today, 'Omotenashi' is very much alive at Lexus and in our products. In fact, it's a constant source of inspiration. Take the NX, for example. Even before you get behind the

wheel, our crossover is already preparing a special 'Omotenashi' welcome. As you approach the car, the door handles light up to greet you and the ground beneath the doors is illuminated to help you avoid stepping into puddles. Once inside, you become aware that everything you need for your comfort and convenience has been thoughtfully placed exactly where you need it - down to the smallest details, like the make-up mirror or the

innovative cupholder that allows you to take the cap off a water bottle using just one hand. The driver-focused cockpit gently embraces you, making you feel both secure and in control. Then, as you drive off, Lexus Safety System + will support your natural driver skills, helping you stay in lane, assisting you in heavy traffic, watching for hazardous situations with other road users, and even taking action should it be needed.







PERFORMANCE

- 01 F SPORT - a dynamic expression of NX's sporting character with exclusive design features
- 02 Luxurious interior with abundant natural light from the panoramic roof
- 03 The mid-size crossover that stands out in the city with radical lines and distinctive profile



01

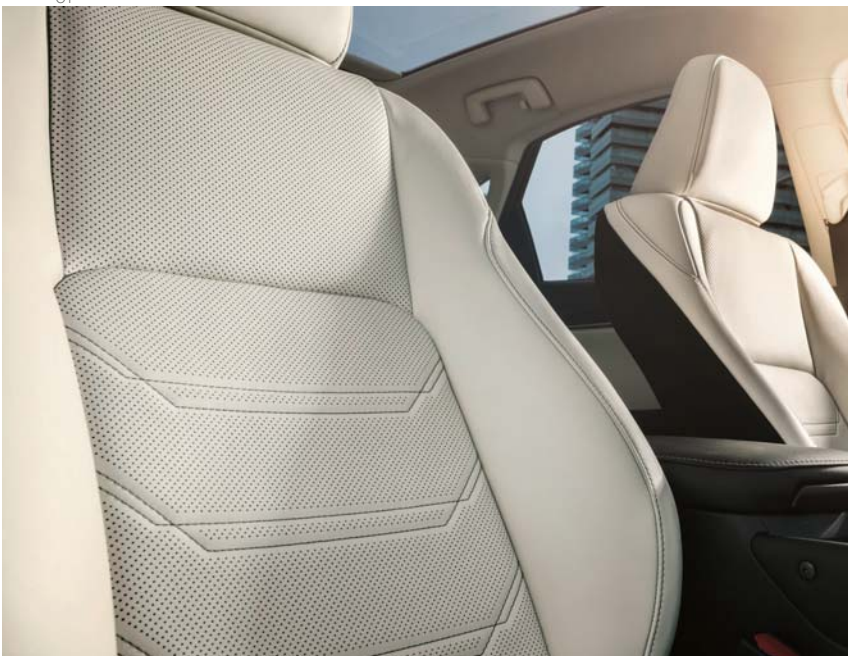

02

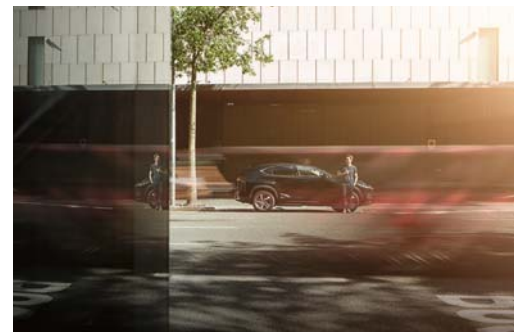

03

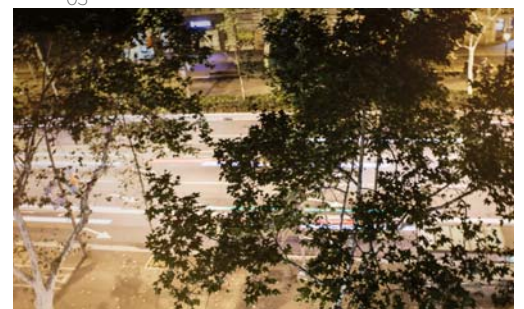

POISED FOR THE CITY

Embrace the chaos. This 21st century maxim is probably the key to navigating almost any major city by car, just as it is in downtown Barcelona. Traffic is pandemonium in the Catalan capital this afternoon, with clamour and colour at every corner. Undoubtedly a little wearing for the everyday commuter, for the casual visitor it's deeply exciting.

It helps that we are in no particular hurry. My driving companion is Takeaki Kato, Chief Engineer on the NX project and a respected figure in automotive engineering, having led the development of numerous Lexus models. Halted at traffic lights, taking in the sights, we are discussing the importance of good posture.

"City driving can often feel suffocating because your position is low down, you can't see what's ahead and it seems like everything is pressing down on top of you," Kato says with an emphatic sweeping motion of the hands. "Bad posture creates pressure and it makes little things like traffic congestion seem much worse than it really is."

Good posture is a feature of the NX crossover, a mid-sized SUV vehicle that has been built specially for urban driving. The seating position is much higher than usual so we have an excellent view of the traffic, a view that is complemented by the feel of the beautifully finished leather seats. It's easier to embrace the chaos when you are comfortable.

It's not just our high position that offers excellent visibility. The Panoramic View Monitor provides images from four separate cameras (front grille, door mirrors and tailgate) with an on-screen guide for tight parking spaces and careful manoeuvring in cluttered streets.

These streets are certainly cluttered but we are moving again, now along one of the airy, tree-lined avenues skirting the edge of Barcelona's celebrated gothic quarter. There is a stunning mural of a mother and baby emblazoned on the side of a building, and the occasional tantalising view of labyrinthine streets teeming with tourists.

As the traffic gathers pace, the NX 300h switches automatically from EV (Electric Vehicle) mode into hybrid operation and we cruise towards the port, enjoying the sensation of movement and the effortless power surging from the drivetrain. "The crossover is a quintessentially urban vehicle so it's got that punch," Kato tells me. "It's really a lot of fun to drive."

The punch comes with poise. The NX has the luxurious feel you expect, and is packed with intuitive technology to enhance the drive experience. The overhead cabin light senses when you want to turn it on. The tailgate remembers how far you usually open it. And those magnificent leather seats can be either heated or ventilated.

Then there's the sound. We are playing around with the 14-speaker Mark Levinson® Premium Surround system, exploring the acoustic properties of the GreenEdge™ technology. Opera has never sounded so pure, so overwhelmingly rich. It's a fitting soundtrack in this amazing city of culture.

We're back among the densely-packed streets, slowly completing a loop that will bring us to our destination: La Sagrada Familia, Gaudi's iconic (and unfinished) basilica. Busy cafes and restaurants give each neighbourhood a distinctive village feel while the afternoon sun cascades through the NX 300h's panoramic roof.

On our way to visit a work of art, it feels like we've already discovered one. The NX design team apparently took their inspiration from the elegant beauty of molten metal, and they have produced something extraordinary: an urban crossover that combines strength with sinuous grace.



EXPLORE YOUR WORLD USING PIONEERING TECHNOLOGY

E-FOUR

Those who adventure far beyond the city's boundaries might like to choose our NX 300h All-Wheel Drive models. With an innovative E-FOUR drivetrain, they deliver seamless performance and confident traction over rougher terrain, with instant torque on demand.

2.0-LITRE TURBO ENGINE

At Lexus we have a passion for performance. Our 2.0-litre turbo engine delivers fast throttle response, exhilarating performance and high torque at low engine revs. We've used groundbreaking technology to achieve a superb balance of fuel economy, refinement and driving pleasure.



LEXUS SAFETY SYSTEM +

The latest Lexus Safety System + includes a Pre-Collision System, now with pedestrian detection at night and bicycle detection during daytime; Lane Tracing Assist to help you stay on course; Adaptive High-beam System for enhanced vision at night; and Dynamic Radar Cruise Control with integrated Road Sign Assist that recognises traffic signs.

EV (ELECTRIC VEHICLE) MODE

When you're driving in heavy city traffic or enclosed car parks you might prefer to travel in EV mode: it's near silent, emissions-free and consumes no fuel. EV mode lets you drive at lower speeds over shorter distances using just electric power.



DRIVE MODE SELECT

Drive Mode Select enables you to change the car's driving behaviour according to your preferences. Which blend of efficiency, dynamism and refinement do you want at any particular moment? The choice is yours.



BLIND SPOT MONITOR & REAR CROSS TRAFFIC ALERT

We've harnessed the power of radar to protect you. For example, if on the motorway you indicate to change lane and a vehicle enters the blind spot of your mirrors, you'll receive a warning signal. Or, if you're reversing out of a parking space and another vehicle approaches the area behind your NX, you'll be alerted.

- 01 Beautiful leather stitching and exquisite detailing
- 02 Large aperture glass sunroof, 18-inch aluminium wheels

THE STUDIO: WHERE STREET DESIGN MEETS 'TAKUMI' TECHNIQUE

At every housewarming party, there comes a ritual moment when each guest is led away for the grand tour. For anyone who loves interior design, this is the exquisite moment of discovery when you finally get to see, for the first time, what your hosts have done with the place.

This feels like one of those moments. We are in the high-security Lexus design studio in Aichi Prefecture, Japan. Hidden away in this four-storey, glass-fronted building - in collaboration with design studios in California and the Côte d'Azur - Lexus prototypes and concept models are created.

I am here at the invitation of Momoko Okamoto of the design development division at Lexus, for an exclusive preview of the mid-size NX crossover. I have heard a lot about Momoko-san, whose work on the ES, LFA and CT models has earned her critical acclaim and a reputation as one of the industry's most dazzling interior colour designers.

We have already passed through a series of studios and workshops where Momoko has exchanged greetings with craftsmen - who wave at us with clay-encrusted hands - and viewed a mocked-up, bare-metal NX body, stripped of wheels, drivetrain, bonnet and tailgate. All work is overseen by 'Takumi' master craftspeople. Their attention to detail is the stuff of legend, checking every aspect of production from the first sketch to the final typhoon test each model undergoes before delivery.

After weeks of waiting, I am finally close enough to touch the NX - my hand is resting impatiently on the door handle - and the anticipation is enormous. Momoko sees how eager I am to wrench open that door, and decides to tease me a little.

"Shall we break for coffee?" she asks, with a straight face. My goggle-eyed reaction is clearly to her liking, and the studio echoes with laughter as her façade of innocence crumbles. "What are you waiting for?" she grins. "Jump in!"

You have to love her sense of humour. Of course, there is no question of 'jumping' into this priceless, pre-production interior mock-up. Rather, I ease myself in the driver's side, in the manner of someone stepping onto a frozen lake.

The visual impression is fantastic, a colour palette that combines force with finesse in an unmistakably urban way.

"The NX is a crossover so it needs to have that edginess and attitude that comes from the streets," Momoko says. "We wanted to be aggressive and challenging with our colour design but also with a strong sense of luxury that elevates the experience of driving and gives every journey a freshness." What makes the NX so special is that we have combined a contemporary urban design attitude with the refinement and quality execution of our 'Takumi' craft tradition.

The sense of luxury is reinforced by the leather seats that are such a hallmark of the brand. The motorsport-inspired foam technology creates a sort of cocoon effect, providing an exceptional level of comfort and support.

CRAFTSMANSHIP



01



02

CRAFTSMANSHIP

- 01 Large 10.3-inch Lexus Premium Navigation display
- 02 Innovative cup holder allows you to take the cap off a water bottle using just one hand
- 03 Twinkling stud on the knee bolster is the same as the one on the LFA supercar
- 04 Refined elegance of hand-finished Shimamoku inlay



01



01



02

The NX not only inherits the intricate 'Shimamoku' ornamentation - the quintessentially Japanese dark-upon-light wood veneers - but takes it to a higher level. Here, an additional finish known as 'steel kenma' sees the gloss slightly buffed with abrasives; it is the same process used by Yamaha on its Europe-bound grand pianos.

Lots to admire. There's an intuitive Touch Pad that lets front seat occupants interact with the central 10.3-inch display. It's as easy to use as a smartphone or tablet. There's a cup holder, made of high-friction elastomer, that allows you to unscrew a bottle cap with one hand. And there's a small, lined container in the centre console that features a detachable lid, which doubles up as a vanity mirror.



04



03

The tour is almost over. As we open our doors, something catches my eye. Are those...? "Yes, great spot!" Momoko laughs. The tiny, twinkling studs on the knee bolsters are indeed the same as the ones on the LFA supercar. "You have a good eye," she says graciously.

I have an okay eye. I see things that are there. Momoko Okamoto, on the other hand, has a truly exceptional eye. She sees things that are not there and fills them in with colours and textures that combine to spectacular effect. Worth seeing for yourself.



F SPORT

ENJOY A NEW KIND OF URBAN SOPHISTICATION

The NX has been designed to relax the urban driving experience so that you can enjoy every minute and arrive refreshed and reinvigorated. It starts with the superb driving position: seated well above most other traffic, you'll enjoy a great view of the city.

And, thanks to Lexus Premium Navigation, you'll find your way through the streets easily. With vivid 3D graphics and many mapping options, the 10.3-inch screen is crystal clear and simple to read. You can operate it by Touch Pad or voice commands. And we haven't forgotten that your journey doesn't always end when you leave the car: the system can even generate a QR code for your smartphone, to help you reach your final destination on foot. (And don't worry about your phone losing charge - there's a wireless charger in the console box to top up your mobile's battery.)

We've made manoeuvring easier too. The Panoramic View Monitor provides images from four discreet cameras. These are located on the front grille, door mirrors (they even work when the mirrors are folded in) and tailgate - with on-screen digital guides to help you weave your way through narrow spaces.

The 14-speaker Mark Levinson® Premium Surround system with GreenEdge™ technology is tailored to the acoustic properties of the NX. You'll enjoy thrilling sound that's equal to the best digital home-theatre experience - utterly vivid and compelling.

The climate control system (which has independent controls for the driver and front passenger) is dedicated to your comfort and wellbeing. It has the ability to remove pollen particles, suppress stale smells and keep the air fresh even when you're parked up. It's economical too, only controlling the climate of the seats that are occupied.



01



02



03

- 01 Intuitive Touch Pad control
- 02 14-speaker Mark Levinson® Premium Surround system with GreenEdge™ technology
- 03 Climate control with independent settings for the driver and front passenger



In this brochure we invite you to prepare for the excitement of choosing your Lexus NX. Showcasing the latest in Lexus design, the NX features a bold Lexus signature grille with stylish smoked chrome details and sporty LED headlights.

Whichever powertrain you select - the pioneering NX 300h Self-Charging Hybrid or dynamic NX 300 petrol turbo - you will find the NX a great pleasure to drive, with a chassis that delivers impressive urban agility.

The cockpit of the NX is more sophisticated than ever. The large 10.3-inch multimedia display is easy to read, and intuitive to control via a large central Touch Pad device. Ultra-precise leather stitching and finely machined switchgear give the cabin an air of modern elegance and refinement.

The NX can be equipped with our latest Lexus Safety System + that now includes a Pre-Collision System with pedestrian detection at night and bicycle detection during daytime.

For a more dynamic experience, you can choose the NX F SPORT featuring an exclusive mesh grille, more responsive suspension, F SPORT interior and distinctive new wheels.

SELECT

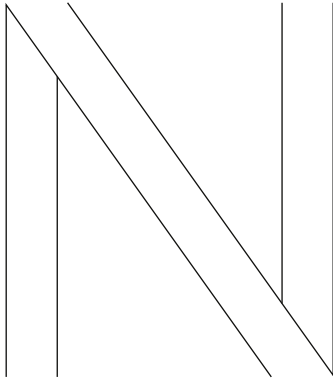

NX 300 | NX 300h

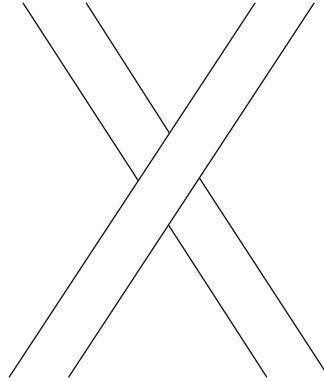

01. MODELS

Choose the dynamic NX 300 petrol turbo or the pioneering NX 300h Self-Charging Hybrid.

Pages 24-29



02. GRADES

What kind of NX best fits your lifestyle? Select from Eco, Comfort, Sport, Business, Executive, F SPORT and Luxury grades.

Pages 30-31



03. FEATURES

Discover the amazing level of standard and exciting optional features available for your NX crossover.

Pages 32-34

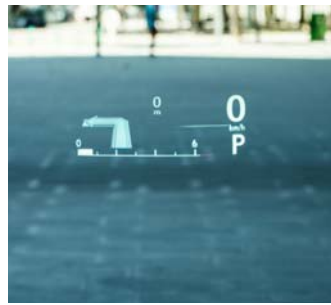

04. TECHNOLOGY

Learn more about NX technologies such as Lexus Safety System +, S-Flow Climate Control and Lexus Premium Navigation.

Pages 35-38



05. ACCESSORIES

Explore the great range of accessories created by Lexus to enhance your enjoyment of the NX.

Page 39



06. Sport

Discover the sharp styling on the brand new NX Sport models.

Page 40



07. F SPORT

For a more dynamic experience, discover the NX F SPORT.

Page 41

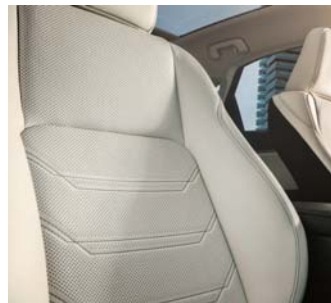

08. COLOURS

Select your favourite exterior colour and specify a 'Takumi'-crafted interior that will make you feel at home every time you drive your NX.

Pages 42-47



09. EQUIPMENT

The NX comes with a wide range of equipment as standard. Learn more about the extras you can add.

Pages 48-55



10. TECHNICAL DATA

Study all the key NX 300 and NX 300h technical data before ordering your NX crossover.

Pages 56-57

THE NX 300

Powered by a turbocharged direct injection 2.0-litre petrol engine, the dynamic NX 300 gives an immense boost to your crossover enjoyment, offering rapid acceleration, confident motorway performance and Lexus refinement. Short-stroke paddle shift controls on the steering column allow you to make quick shifts without removing your hands from the steering wheel.



Stunning Mercury Grey bodywork,
18" alloy wheels.

THE NX 300h

Powered by a Lexus Self-Charging Hybrid - which seamlessly orchestrates power from a 2.5-litre petrol engine and electric motor(s) - the NX 300h is incredibly smooth and quiet, yet as easy to drive as a conventional luxury car. Delivering lively performance, it achieves amazing fuel economy for a crossover of this size.



Stunning Graphite Black bodywork,
18" alloy wheels.

01. 2.0-LITRE TURBO ENGINE

Featuring a breakthrough combination of water-cooled cylinder head, integrated exhaust manifold and twin scroll turbocharger, this 2.0-litre turbo engine delivers fast throttle response, exhilarating performance and high torque at low engine revs. For enhanced fuel economy, innovative valve timing allows the engine to switch between the Otto and Atkinson cycles. Tested in extremely harsh conditions - including weeks of mountain pass driving at 3,000 m in over 50° C of heat - this engine supplies a maximum output of 175 kW (238 DIN hp) with a maximum torque of 350 Nm.

02. D-4S

Depending on the driving situation, this advanced injection system distributes the fuel load between the higher-pressure direct injectors in the cylinder, and the lower pressure port injectors. Giving optimum combustion at all times, D-4S ensures enhanced fuel economy and excellent low-speed torque.

03. TURBOCHARGER

This highly efficient twin scroll turbocharger has been engineered to produce high torque right through the rev range. The shape of the turbine blades has been optimised, and the friction in the bearing mechanism reduced, creating a compact high-efficiency turbocharger with incredibly responsive performance.

04. 6-SPEED AUTOMATIC TRANSMISSION

The NX 300's 6-speed automatic transmission is designed to provide maximum power from the turbo engine. Thanks to its torque-demand control logic, the system optimises the required engine torque at any given moment, ensuring quick throttle response and high fuel efficiency.



01/02



03



04

01. 2.5-LITRE PETROL ENGINE

A highly efficient 155 DIN hp 'Atkinson Cycle' 4-cylinder petrol engine, with VVT-i valve control and optimised electronic fuel injection, forms the heart of the NX 300h's Self-Charging Hybrid powertrain. Start/Stop technology and exhaust heat recycling help reduce fuel consumption and emissions even further.

02. LEXUS SELF-CHARGING HYBRID

No larger than a conventional automatic transmission, Lexus Hybrid Drive's front electric motor, generator and power split mechanism are all housed in one highly compact hybrid transmission. Energy flows are managed by an advanced Power Control Unit that constantly optimises the allocation of power - electric, petrol or a combination of both.

03. HYBRID BATTERY

Featuring an innovative split design, and located under the rear seat so as not to encroach on the NX 300h's large luggage space, the hybrid battery provides high power output in relation to its weight. The NX 300h recharges its hybrid battery as required - using electricity generated when driving and braking - thus avoiding the need for any external charging.



01



02



03

EXPERIENCE A LEXUS HYBRID



START UP, DRIVING OFF

When starting off, the powerful front - and additional rear electric motor on All-Wheel Drive models - can swiftly propel the NX 300h up to 65 km/h, with electric power supplied by the hybrid battery. At this point the vehicle is almost silent, uses no petrol and produces zero emissions.

NORMAL DRIVING CONDITIONS

At speeds above 65 km/h the ultra-smooth Atkinson Cycle petrol engine cuts in quietly while still receiving assistance from the electric motor(s) when required. Through the near perfect distribution of its petrol and electric power sources, the NX 300h provides extraordinary driving enjoyment - together with low emissions and modest fuel consumption.



FULL THROTTLE ACCELERATION

Accelerate powerfully and the power of the electric motor(s) instantaneously supplements the 2.5-litre petrol engine. Together they deliver a potent surge of torque to give breathtakingly fast linear acceleration precisely when you need it.

DECELERATION, STOPPING, BRAKING

When decelerating or coming to a halt, the petrol engine turns off, cutting emissions to zero. Brake, or take your foot off the accelerator, and regenerative braking harnesses the kinetic energy lost in other cars. It converts this into electrical energy for storage in the hybrid battery, which is why a Lexus Self-Charging Hybrid is always ready to go.



17" 10-spoke alloy wheels
Bi-LED headlights
Fabric upholstery

ECO*

As you'd expect from Lexus, this package has a substantial level of standard equipment.

* Only available on hybrid FWD model.

8" fixed central display, Touch Pad operation
2-zone electronic climate control



18" alloy wheels
Integrated roof rails
Analogue clock

COMFORT

The Comfort grade offers NX owners great looks and connectivity.

8-speaker Pioneer® audio system
8" Lexus Media Display, Touch Pad operation



18" alloy wheels
Parking assist sensors, front and rear
LED front fog lights

BUSINESS

Created for the driver whose car is a professional tool, this grade comes with purposeful looks and equipment to make driving more convenient.

Tahara upholstery
Smart entry system
Cornering lights



18" alloy wheels
Privacy glass

EXECUTIVE

The NX Executive grade is distinguished by subtle exterior hallmarks while delivering a high level of comfort.

Leather upholstery
Front seats, 8-way electrically multi-adjustable



Sport

Enjoy NX Sport highlights like a Lexus signature grille framed in black, two-tone 18-inch alloy wheels and black door mirror housings.

18" alloy wheels, black with machined finish or dark-bronze

Sport styling elements:

Black Lexus signature grille, grille frame, door mirrors

Fabric or Tahara upholstery

8-speaker Pioneer® audio system

Lexus Premium Navigation



F SPORT*

For those in search of dynamic SUV looks, the F SPORT grade offers features such as an exclusive Lexus signature grille, F SPORT wheels and sporty interior details.

* Only available on AWD models.

18" alloy wheels, F SPORT design

F SPORT front and rear bumper

Black F-mesh Lexus signature grille

Triple LED headlights

Lexus Safety System +

Front seats, F SPORT design

F SPORT leather upholstery

Drilled aluminium pedals

F SPORT steering wheel and gearshift lever

Active Sound Control

Front and rear performance dampers



LUXURY*

The ultimate NX for looks, refinement and comfort.

* Only available on AWD models.

18" alloy wheels, two-tone finish

Lexus Safety System +

Triple LED headlights

Leather upholstery

10-speaker Pioneer® audio system

Lexus Premium Navigation



01



02

01. 17" ALLOY WHEELS

Only available on the NX 300h – and fitted as standard on the Eco grade – these 10-spoke deep gloss wheels are equipped with 225/65 R17 tyres for low running resistance and excellent functionality.

02. 18" ALLOY WHEELS

Standard on Comfort, Business and Executive grades, this intricate u-shaped spoke design creates a sharp and radical profile, while 225/60 R18 tyres complete the bold sports look.

03. 18" ALLOY WHEELS

Exclusive to Luxury grade this wheel combines a bright machined finish with a dark metallic coating to create a dynamic impression.



03



04

04. POWER TAILGATE

A remote controlled tailgate ensures convenience, especially when your arms are full of shopping. With the key in your pocket or bag, simply place your foot under the rear bumper to open or close the tailgate.

05. SUNROOF

An electric, tilt and slide glass sunroof adds a feeling of freedom, spaciousness and light to the NX.

06. PANORAMIC ROOF

This large glass, factory-fitted panoramic roof provides extra headroom and lets more sunshine into the NX cabin. The panoramic roof is fitted with an electric sliding blind to shade you should the sun become too intense.



05



06

07. BI-LED / ECO DRL

Bi-LED headlights give excellent visibility. They are combined with energy saving Daytime Running Lights. An Automatic High Beam (AHB) function is available.

08. BI-LED / FULL DRL

Fitted standard on Comfort, Business and Executive grades, these higher grades benefit from full LED illumination of the L-shaped Daytime Running Lights.

09. TRIPLE LED 'L' BEAMS / FULL DRL

On F SPORT and Luxury grades, elegant ultra-small 3-beam LED units have been adopted. These are similar to those which were first used on the Lexus LC Coupé. These lights are combined with Daytime Running Lights which have thick-walled inner lenses to create a beautiful crystal glass impression even when not illuminated. Enhancing its sophisticated looks, sequential front and rear LED indicators make the NX stand out even more in traffic.

10. LED REAR LIGHTS

The rear light cluster combines elegant LEDs arranged in the signature 'L' form, ensuring that at night your car is recognised as a Lexus at a glance. Thick-wall moulding technology gives a crystal appearance, and a strikingly bold presence when not illuminated.



07



08



09



10



01

01. ERGONOMIC DESIGN

Seat cushion shape and firmness have been optimised to reduce pressure on the sensitive ischial region. For extra comfort, long reach seat adjustments also accommodate larger physiques.

02. HEATED / VENTILATED SEATS

In combination with leather upholstery, the driver and front passenger can heat or ventilate their seats. This adds to the sense of luxury, especially in extreme weather conditions.

03. FLEXIBLE SPACE / POWER REAR SEATS

A practical 60:40 split folding rear seat comes standard on all NX models, which allows easy stowage of larger items like a racing bike or surfboard. With all rear seats folded down there is room to carry bulky objects.

You can also upgrade to a fully electric folding mechanism, which is operated via a number of conveniently located controls. And rear seat passengers can also partially recline their backrests for added comfort.

04. S-FLOW CLIMATE CONTROL

S-Flow intelligently controls the interior climate according to ambient conditions, ensuring excellent comfort and fuel economy.

05. LEATHER STEERING WHEEL

A beautifully crafted leather steering wheel features finger rests and a cross-section optimised to fit comfortably in your hands. Integrated switches control - where specified - audio, telephone, multi-information display, Dynamic Radar Cruise Control and Lane Departure Alert.

For added comfort in colder conditions, the steering wheel can be heated on higher grades. The steering wheel heater is activated by a switch and turns off automatically after a pre-set time.



02



03



04



05

06. LEXUS MEDIA DISPLAY

The NX is available with Lexus Media Display, which features an 8-inch screen and a Touch Pad to adjust audio, climate settings or view the energy monitor. Compatible smartphones can be 'mirror linked' to the display.



06

07. LEXUS PREMIUM NAVIGATION

With vivid 3D graphics and many mapping options, the 10.3-inch screen is operated by Touch Pad or voice commands. The system can even generate a QR code for your smartphone, to help you reach your final destination on foot.



07

08. COLOUR HEAD-UP DISPLAY

Vehicle data is projected in colour directly onto the windscreen. This extra-wide 6.2" Head-Up Display lets you check data like navigation commands or audio settings without taking your eyes off the road ahead.



08

09. 8 OR 10-SPEAKER PIONEER® AUDIO

An 8-speaker Pioneer® audio system is fitted as standard. This features an AM/FM RDS tuner, CD player and Bluetooth® connectivity. The 10-speaker upgrade has a DAB tuner and DVD player and offers greater fidelity with 16 cm speakers in the front doors.

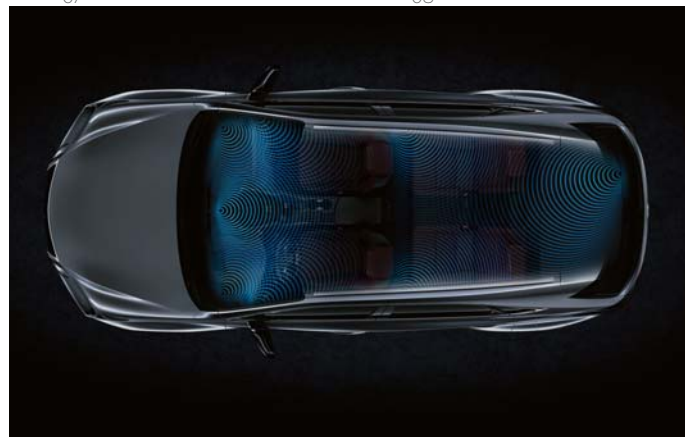

09

10. MARK LEVINSON®

The 14-speaker Mark Levinson® Premium Surround system with GreenEdge™ technology is tailored to the acoustic properties of the NX. It delivers a peerless 7.1-channel digital home-theatre experience enhanced by Clari-Fi™ that rebuilds sound lost in MP3 digital compression.



10

11. WIRELESS CHARGER

Charge compatible smartphones or other electronic devices using the inductive wireless battery charger, conveniently positioned in the NX's centre console box.



11



01

01. 8 AIRBAGS

In addition to an immensely strong passenger safety cell, occupant protection is provided by eight airbags. The driver and front passenger are protected by 2-stage head airbags, as well as knee and side airbags. Curtain shield airbags run the full length of both cabin sides. All seatbelts are also specified with pre-tensioners.

02. TYRE PRESSURE WARNING SYSTEM

Receiving data from a sensor installed in each tyre, the multi-information display tracks tyre pressure data and warns accordingly should pressure drop in one or more tyres.



02



03

03. WHIPLASH INJURY LESSENING SEATS

The front seats are designed to minimise whiplash inducing neck motion in a rear impact. Reinforced seat frames allow the torso to sink into the seatback, while the placement of the headrest supports the head more effectively.

04. PARKING ASSIST MONITOR

To make parking even easier, sensors in the rear bumper link with an in-car beeper to warn of obstacles in your way. The beeper can be turned off when not required. Engage reverse and the view behind the NX is relayed to the 10.3-inch display, complete with on-screen guides to assist parking.



04



05

05. PANORAMIC VIEW MONITOR

For easier driving in confined spaces, four cameras provide a near-360° view around the entire vehicle. A Lexus first, Panoramic View Monitor also creates a virtual 3D view of your NX, with on-screen guides to assist close-quarter manoeuvring in the city.

06. BLIND SPOT MONITOR & REAR CROSS TRAFFIC ALERT

Radar devices mounted in the rear bumper detect vehicles in adjacent lanes that are not visible in the door mirrors. If the driver is indicating to change lane and a vehicle enters the blind spot, a warning signal appears in the relevant door mirror(s).

The Rear Cross Traffic Alert function uses Blind Spot Monitor radar to detect vehicles approaching the area behind the vehicle in a car park. When necessary, it alerts you with a buzzer and a visual display in the door mirrors.



06

07. LEXUS SAFETY SYSTEM +

Available on the NX, Lexus Safety System + includes the following features:

08. PRE-COLLISION SYSTEM & PEDESTRIAN DETECTION

The Pre-Collision System on the NX can now even detect pedestrians at night and bicycles during daytime. To achieve this, the camera sensitivity and dynamic range have been enhanced to help reduce accidents in the dark, for example, when a pedestrian in front of an oncoming vehicle is difficult to see due to the vehicle's lights. Furthermore, the millimetre-wave radar detection area angle has been widened, enabling bicycles to be detected. If the system judges that the possibility of a collision is high, the brakes are automatically applied to support collision avoidance, or reduce damage in the event of a collision.

09. DYNAMIC RADAR CRUISE CONTROL

The system uses the millimetre-wave radar sensor and a camera to detect the vehicle in front and provide control to maintain an appropriate distance. If the vehicle in front comes to a halt, the system will stop the NX. When the vehicle moves off again, the NX will start off and continue following.

10. LANE DEPARTURE ALERT / LANE TRACING ASSIST

Lane Departure Alert (LDA) uses a camera in the front windscreen to monitor your position in lane. If you start drifting out of lane, LDA will activate a warning buzzer and give brief corrective steering input.

On F SPORT and Luxury models, Lane Tracing Assist goes one step further and is also capable of providing more assistance when driving around bends with a tighter radius.

11. AUTOMATIC HIGH BEAM / ADAPTIVE HIGH-BEAM SYSTEM

Automatic High Beam detects oncoming vehicles at night and automatically dips the high beam headlights. This reduces the chance of accidentally dazzling other drivers and lets you concentrate on the road ahead.

On F SPORT and Luxury models, the Adaptive High-beam System also prevents the NX from dazzling other road users. Independent LED chips in the headlights are enabled/disabled for precise control of the illuminated and non-illuminated areas.

12. ROAD SIGN ASSIST

The Road Sign Assist (RSA) system available on the NX recognises traffic signs and provides information to the driver via the multi-information display. When linked to Dynamic Radar Cruise Control, the crossover's speed setting can be quickly reset in accordance with the speed limit recognised by RSA.



07



08



09



10



11



12

Under no circumstances should Lexus Safety System + be used to replace your driving skills at the wheel. Please read the instructions very carefully before operating the system and remember the driver is always responsible for safety. Details of specifications and equipment are subject to change to suit local conditions and requirements. Please enquire at your local Lexus Authorised Retailer.



01

01. EXTREMELY STRONG CHASSIS, ADAPTIVE VARIABLE SUSPENSION

With its sophisticated chassis, suspension and steering, the NX is incredibly smooth and refined to drive. Advanced laser screw welding and adhesive bonding techniques also make it extremely rigid. This has produced a crossover of great strength, which rewards drivers with superior handling characteristics. Equipped with compact MacPherson strut front suspension and sophisticated double wishbone rear suspension, the NX gives outstanding road holding, sedan-like cornering characteristics and superb straight-line stability. For a more engaging drive, optional Adaptive Variable Suspension intelligently controls the damping force on all four wheels. This not only improves ride comfort, but also increases handling stability.



02

02. ADVANCED AERODYNAMICS

The NX has excellent aerodynamics, thanks to a near-flat underbody and large rear spoiler. To reduce the overall drag coefficient, Lexus engineers also redesigned the door mirrors. These measures not only enhance stability and handling, they also improve fuel efficiency and reduce wind noise.

03. DRIVE MODE SELECT

Located on the centre console, next to the gearshift, Drive Mode Select allows drivers to choose between Eco, Normal / Custom, Sport S / Sport S+ modes, for maximising the car's efficiency, dynamism or refinement.



03



04

04. E-FOUR

On NX 300h All-Wheel Drive models, E-FOUR delivers seamless performance and confident traction over rougher terrain. The innovative E-FOUR drivetrain features the addition of a 68 DIN hp electric motor mounted on the rear axle, which supplies instant torque on demand.

05. HILL-START ASSIST CONTROL

Hill-start Assist Control maintains brake pressure to help prevent the NX from moving backwards when starting off on a slope. Hill-start Assist Control also minimises wheel-spin on slippery inclines.



05

01. TEXTILE FLOOR MATS

Luxurious black textile mats made of acuvellour to improve the sound absorbing qualities of your car's carpets. The driver's mat has a safety fixing to prevent it from slipping.

02. FRONT SKIRT

Designed to enhance your car's look of power and individuality. The Lexus front skirt integrates with, and complements, the NX's front bumper.

03. REAR SKIRT

With its wrap-around styling, the Lexus rear skirt extends the depth of the NX's rear bumper to establish a dynamic, sporty appearance. (The rear skirt accessory for the NX 300 will be available mid 2019.)

04. DETACHABLE TOWING HITCH*

Integrates with the NX's chassis to evenly distribute the pulling and braking forces of towing, thus minimising the risk of stress damage to your crossover. It has a 1500 kg towing capacity and the hitch removes when not required. The purpose-designed wiring kit includes safety buffers to shield your car's electrics against faults in the trailer's system.

*Not available on NX 300h FWD models.

05. BOOT LINER

Made of tough, flexible plastic with a non-slip surface pattern and a raised lip around the edges to comprehensively protect the luggage space carpet against mud, dirt, sand and liquids.

06. 17" WINTER ALLOY WHEELS

Lexus winter alloy wheels are purpose designed to equip your NX for poor road conditions and low temperature driving while maintaining a prestige appearance.

07. 18" ALLOY WHEELS

The black mirror chrome finish and high performance 10-spoke design create an unmistakable look of urban sophistication.

08. 18" SILVER MACHINED FACE ALLOY WHEELS (5 DOUBLE-SPOKE)

A sports inspired multi-spoke design highlighted by its reflective silver finish and machined face on alternating spokes.

09. 18" BLACK MACHINED FACE ALLOY WHEELS (5 DOUBLE-SPOKE)

Sporty multi-spoke design in a gloss black finish with individual spokes machined to expose the underlying alloy.



01



02



03



04



05



06



07



08



09



01. BLACK LEXUS SIGNATURE GRILLE

The new NX Sport models feature an exclusive black Lexus signature grille that enhances the NX's powerful appearance.

02. BLACK DOOR MIRRORS

Factory fitted black door mirrors underline the dynamic stance of the new NX Sport.

03. 18" ALLOY WHEELS

Distinctive 5-twin-spoke alloy wheels with a two-tone metallic finish enhance the NX Sport's dynamic character.

04. 18" ALLOY WHEELS

Head turning 5-twin-spoke alloy wheels with a two-tone bronze finish create an unmistakable look.

05. UPHOLSTERY

Everything you touch in the new NX Sport displays peerless Lexus quality - from the leather-covered steering wheel to the exclusive upholstery options.



01



02



03



04

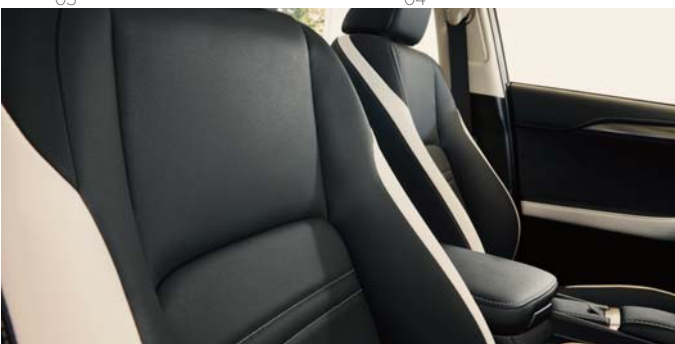

05

01. F SPORT DESIGN

A bolder Lexus signature grille with an exclusive mesh pattern accentuates the NX F SPORT's dynamic looks. Further exclusive details like an F SPORT badge (incorporating the curves of the Fuji Speedway), black door mirrors, distinctive 18" F SPORT alloy wheels, rear bumper and spoiler all express the car's strong character.



01

02. 18" F SPORT ALLOYS

Exclusive to F SPORT, with a dark premium metallic finish, these extremely distinctive 5-twin-spoke alloy wheels underline the vehicle's dynamic character.



02



03

03. 18" F SPORT ALLOYS

For an exciting new F SPORT look, these alloy wheels combine an exclusive colour - Black with machined finish - and a highly textured appearance.

04. F SPORT INTERIOR

The F SPORT interior is available in black leather and exclusive leather upholstery colours Flare Red and Mustard Yellow, together with unique ornamentation and stitching. Exclusive F SPORT seats feature 'integrated foaming' technology for added lateral support while cornering. Aluminium inlays perfectly complement the beautifully crafted F SPORT steering wheel, inspired by that of our iconic LFA supercar. Finished in perforated leather, the F SPORT gearshift design matches the steering wheel to create an exciting sports look. Drilled aluminium pedals add further excitement to the interior.



04

05. G-SENSOR

For a more engaging drive, a G-Sensor displays the NX F SPORT's lateral and longitudinal G-forces in the multi-information display. The screen also displays the steering angle, throttle position, and hydraulic brake pressure.

06. BOOST METER

The NX 300 F SPORT features a boost meter that tracks the dynamic performance of the engine's turbo. The display also shows the temperature and oil pressure data.



05



06

DEVELOPING A NEW LEXUS PAINT COLOUR IS BOTH COMPLEX AND TIME CONSUMING



Lexus designers never use off-the-shelf colours, preferring instead to develop their own, from scratch, a process that can take up to two years. The Lexus paint palette totals some 30 different colours including metallic finishes like Sonic White and Sonic Titanium.

There are no shortcuts to creating a new Lexus colour: A designer's decision comes only after going through hundreds of samples. "When developing a new colour I see so many shades of paint that I sometimes can't see straight at the end of the day," says Megumi Suzuki, one of our most experienced colour designers. To do her job, it takes a grasp of chromogenics and a keen eye.

"Every time I meet someone or walk into a shop or go to someone's house, I check out colours and materials," she says. "There are a lot of people like me in our division."

Even after a colour has been decided upon, there's plenty to do. At various stages during development, Suzuki had to enlist a small army of experts: Lab technicians who mix the paint, clay sculptors, engineers and the assembly-line paint shop crew who would give each car a flawless, uniform coat. Every few weeks Kansai Paint (a Lexus paint supplier) produces a new batch, and Lexus designers give the samples a thorough look-over, bending the test panels to mimic the contours of a car. All are scrutinised indoors and outdoors, under floodlights, in sunlight, shade and overcast conditions, and at different times of the day and months of the year.

Selecting the final colour is not easy. A colour that is dazzling on a summer morning can appear sickly in the shade or under showroom lights. Designers also have to contend with the vagaries of their own preferences. "The odd thing about colour is that your perception of it can change depending on the season, how you feel that day and the trends you're seeing," says Suzuki.

F WHITE | 083¹



SONIC WHITE | 085



SONIC TITANIUM | 1J7



MERCURY GREY | 1H9



BLACK | 212³



GRAPHITE BLACK | 223



MORELLO RED | 3R1

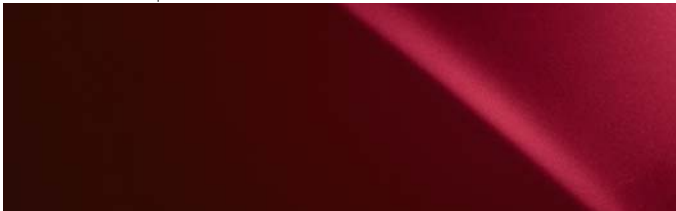

COPPER BROWN | 4X2²



BLAZING CARNELIAN | 4Y1



SOLAR FLARE | 4W7¹

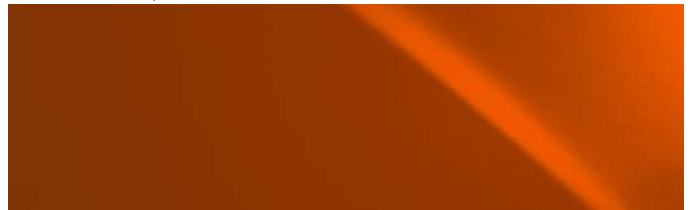

SKY BLUE | 8X9²



SAPPHIRE BLUE | 8X1¹



¹Exclusive to F SPORT.
²Not available on F SPORT.
³Solid colour

Please note: due to printing variances, actual paintwork colours may vary slightly from those illustrated.

FABRIC¹



Black

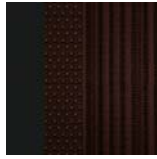

Dark Rose

TAHARA TRIM²



Black



White Accent



Rich Cream



White Ochre



Dark Rose

LEATHER³



Black

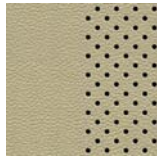

Rich Cream



White Ochre



Ochre



Dark Rose



Sunflare Brown
Accent

F SPORT LEATHER⁴



Black



White



Flare Red

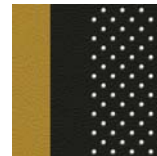

Mustard Yellow

INLAYS⁵



Piano Black

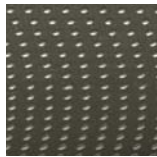

Silver



Black Shimamoku



Bamboo



Dark Brown

F SPORT INLAYS⁶

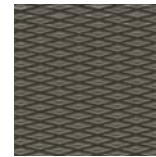

Dark Mesh Metal

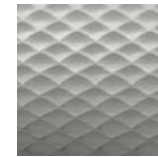

Naguri-Style
Aluminium

¹ Fabric upholstery is standard on Eco and Comfort grades. The Eco grade is supplied in Black.

² Tahara trim is standard on Business grade. It can also be specified as part of a cost option pack on Comfort and Sport. White Ochre can be ordered in combination with either Black or matching White Ochre instrument panel and door panels.

³ Leather is standard on Executive and Luxury grades. White Ochre and Rich Cream can be ordered in combination with either Black or matching instrument panel and door panels.

⁴ F SPORT leather in a unique design and exclusive colours is standard on F SPORT.

⁵ F SPORT leather in a unique design and exclusive colours is standard on F SPORT. Black inlays are standard on Eco and Comfort grades. Silver inlays are standard on Sport, Business and Executive grades and can be specified as an option or part of a pack on Comfort. Dark Brown inlays are optional on Executive grade. Black Shimamoku or Bamboo inlays are standard on Luxury.

⁶ Dark Mesh Metal inlays are standard on F SPORT, while Naguri-Style Aluminium is available as an option.

The images on the following 3 pages illustrate a selection of the interior combinations available. Your local Lexus Authorised Retailer will be pleased to provide you with any further help.



01



02



03

- 01 Black fabric with Piano Black inlays (Comfort)
- 02 White Accent Tahara trim with Silver inlays (Sport)
- 03 Dark Rose Tahara trim with Silver inlays (Business)



04



05



06

- 04 Black leather with Black Shimamoku inlays (Luxury)
- 05 Rich Cream leather with Black Shimamoku inlays (Luxury)
- 06 Sunflare Brown Accent leather with Dark Brown inlays (Luxury)



07



08



09

- 07 Black F SPORT leather with Dark Mesh Metal inlays (F SPORT)
- 08 Flare Red F SPORT leather with Naguri-Style Aluminium inlays (F SPORT)
- 09 White F SPORT leather with Naguri-Style Aluminium inlays (F SPORT)

EQUIPMENT | GRADES

EXTERIOR	ECO*	COMFORT	Sport	BUSINESS
Auto-levelling headlights	■	■	■	■
Cornering lights ¹	-	■/○	■/○	■
Daytime running lights, LED	■	■	■	■
Door mirrors, electrically adjustable and folding, heated	■	■	■	■
Door mirrors, electrically adjustable with memory, auto-folding, electro chromatic (auto-dimming), heated	-	-	-	-
Door mirrors, integral turn signal indicators	■	■	■	■
F SPORT logos, front fenders	-	-	-	-
F-mesh Lexus signature grille	-	-	-	-
Front bumper, F SPORT design	-	-	-	-
Front fog lights ¹	-	■/○	■/○	-
Headlight cleaners	○	○	○	○
Headlights, bi-LED	■	■	■	■
Headlights, triple LED	-	-	-	-
Integral roof rails	-	■	■	■
Intelligent Parking Sensors (IPS), front and rear	-	-	-	-
Lexus signature grille	■	■	■	■
Parking assist sensors, front and rear	-	-	-/■	■
Privacy glass	-	-	○	○
Rain sensing windscreen wipers	□	■	■	■
Rear bumper, F SPORT design	-	-	-	-
Rear combination lights, LED	■	■	■	■
Sequential indicators	-	■	■	■
Sport styling package	-	-	■	-
Tailgate, electrically operated	-	-	-	○
Tailgate, electrically operated with kick-open function	-	-	-	-

WHEELS

17" alloy wheels, 10-spoke design, 225/65 R17 tyres ²	■	○	-	-/○
18" alloy wheels, 5-twin-spoke design, 225/60 R18 tyres	-	■	-	■
18" alloy wheels, F SPORT design, 5-twin-spoke, 235/55 R18 tyres	-	-	-	-
18" alloy wheels, machined design, two-tone finish, 225/60 R18 tyres	-	-	■	-
18" alloy wheels, two-tone finish, 225/60 R18 tyres	-	-	-	-
18" alloy wheels, dark bronze two-tone finish, 225/60 R18 tyres	-	-	○	-

ACTIVE SAFETY AND DRIVING DYNAMICS

Active brake lights	■	■	■	■
Adaptive High-beam System (AHS)	-	-	-	-
Adaptive Variable Suspension (AVS)	-	-	-	-
Anti-lock Braking System (ABS)	■	■	■	■
Automatic High Beam (AHB)	□	□	□	□
Blind Spot Monitor (BSM) with Rear Cross Traffic Alert (RCTA)	-	-	-	-
Cruise control	■	■	■	■
Drive Mode Select (Eco - Normal - Sport)	■	■	■	■
Drive Mode Select (Eco - Normal / Custom - Sport S / Sport S+)	-	-	-	-
Dynamic Radar Cruise Control (DRCC), all-speed	□	□	□	□
Electronic Parking Brake (EPB)	■	■	■	■
EV (Electric Vehicle) mode (NX 300h)	■	■	■	■
Front performance rod	■	■	■	■
Hill-start Assist Control (HAC)	■	■	■	■
Lane Departure Alert (LDA) with Sway Warning function	□	□	□	□
Lane Tracing Assist (LTA)	-	-	-	-
Pre-Collision System (PCS)	□	□	□	□
Performance dampers, front and rear	-	-	-	-
Road Sign Assist (RSA)	□	□	□	□
Sports suspension	-	-	-	-
Traction Control (TRC)	■	■	■	■
Vehicle Stability Control (VSC)	■	■	■	■

EXTERIOR	EXECUTIVE	F SPORT	LUXURY
Auto-levelling headlights	■	■	■
Cornering lights ¹	■	■	■
Daytime running lights, LED	■	■	■
Door mirrors, electrically adjustable and folding, heated	■	-	-
Door mirrors, electrically adjustable with memory, auto-folding, electro chromatic (auto-dimming), heated	-	■	■
Door mirrors, integral turn signal indicators	■	■	■
F SPORT logos, front fenders	-	■	-
F-mesh Lexus signature grille	-	■	-
Front bumper, F SPORT design	-	■	-
Front fog lights ¹	■	■	■
Headlight cleaners	○	■	■
Headlights, bi-LED	■	-	-
Headlights, triple LED	-	■	■
Integral roof rails	■	■	■
Intelligent Parking Sensors (IPS), front and rear	-	○	○
Lexus signature grille	■	-	■
Parking assist sensors, front and rear	■	■	■
Privacy glass	■	■	■
Rain sensing windscreen wipers	■	■	■
Rear bumper, F SPORT design	-	■	-
Rear combination lights, LED	■	■	■
Sequential indicators	■	■	■
Sport styling package	-	-	-
Tailgate, electrically operated	○	■	■
Tailgate, electrically operated with kick-open function	○	○	○
WHEELS			
17" alloy wheels, 10-spoke design, 225/65 R17 tyres ²	-	-	-
18" alloy wheels, 5-twin-spoke design, 225/60 R18 tyres	■	-	-
18" alloy wheels, F SPORT design, 5-twin-spoke, 235/55 R18 tyres	-	■	-
18" alloy wheels, machined design, two-tone finish, 225/60 R18 tyres	-	○	-
18" alloy wheels, two-tone finish, 225/60 R18 tyres	-	-	■
18" alloy wheels, dark bronze two-tone finish, 225/60 R18 tyres	-	-	-
ACTIVE SAFETY AND DRIVING DYNAMICS			
Active brake lights	■	■	■
Adaptive High-beam System (AHS)	-	■	■
Adaptive Variable Suspension (AVS)	-	□	□
Anti-lock Braking System (ABS)	■	■	■
Automatic High Beam (AHB)	□	-	-
Blind Spot Monitor (BSM) with Rear Cross Traffic Alert (RCTA)	-	■	■
Cruise control	■	-	-
Drive Mode Select (Eco - Normal - Sport)	■	■	■
Drive Mode Select (Eco - Normal / Custom - Sport S / Sport S+)	-	□	□
Dynamic Radar Cruise Control (DRCC), all-speed	□	■	■
Electronic Parking Brake (EPB)	■	■	■
EV (Electric Vehicle) mode (NX 300h)	■	■	■
Front performance rod	■	-	■
Hill-start Assist Control (HAC)	■	■	■
Lane Departure Alert (LDA) with Sway Warning function	□	■	■
Lane Tracing Assist (LTA)	-	■	■
Pre-Collision System (PCS)	□	■	■
Performance dampers, front and rear	-	■	-
Road Sign Assist (RSA)	□	■	■
Sports suspension	-	■	-
Traction Control (TRC)	■	■	■
Vehicle Stability Control (VSC)	■	■	■

* Only available on NX 300h FWD model.

¹ For the NX Comfort grade, cornering lights and front fog lights are standard on NX 300 and available as an option on NX 300h.² For the NX Business grade, 17" alloy wheels are only available as an option on NX 300h.

EQUIPMENT | GRADES

PASSIVE SAFETY	ECO*	COMFORT	Sport	BUSINESS
Airbag cut-off switch, front passenger	■	■	■	■
Airbags, driver and front passenger; head, side and knee / full-length curtain shield	■	■	■	■
ISOFIX attachment, outer rear seats	■	■	■	■
Seatbelt pre-tensioners, front seats	■	■	■	■
Seatbelt pre-tensioners, rear seats	■	■	■	■
SECURITY				
Anti-theft system - horn	■	■	■	■
Anti-theft system - siren / intrusion sensor	○	○	○	○
Anti-theft system - siren / intrusion sensor / inclination sensor / glass breakage sensor	○	○	○	○
Auto door locking	■	■	■	■
Double door lock	■	■	■	■
AUDIO, COMMUNICATION & INFORMATION				
8" Lexus Media Display	□	■	■	■
10.3" multimedia display	-	□	□	□
8-speaker Pioneer® audio system	□	■	■	■
10-speaker Pioneer® audio system	-	□	□	□
14-speaker Mark Levinson® Premium Surround system	-	-	-	-
2 USB ports and AUX socket	□	■	■	■
Active Sound Control (ASC) ¹	-	-	-	-
Analogue clock with GPS function	□	■	■	■
Antenna, shark fin design	■	■	■	■
Bluetooth® mobile phone and audio connectivity	□	■	■	■
Head-Up Display (HUD)	-	-	-	-
Lexus Premium Navigation	-	○	○	○
Panoramic View Monitor	-	-	-	-
Parking assist monitor with on-screen guides	-	○	○	○
Steering wheel mounted controls - audio / display / phone / voice	■	■	■	■
Steering wheel mounted controls - audio / display / phone / voice / DRCC / LDA	□	□	□	□
Touch Pad operation for central display	■	■	■	■
Tuner with DAB technology ²	□	○	○	○
Wireless charger	-	○	○	○

- Available as standard.
- Available as an option.
- Available as part of a pack.
- Not available.

PASSIVE SAFETY	EXECUTIVE	F SPORT	LUXURY
Airbag cut-off switch, front passenger	■	■	■
Airbags, driver and front passenger; head, side and knee / full-length curtain shield	■	■	■
ISOFIX attachment, outer rear seats	■	■	■
Seatbelt pre-tensioners, front seats	■	■	■
Seatbelt pre-tensioners, rear seats	■	■	■
SECURITY			
Anti-theft system - horn	■	■	■
Anti-theft system - siren / intrusion sensor	○	○	○
Anti-theft system - siren / intrusion sensor / inclination sensor / glass breakage sensor	○	○	○
Auto door locking	■	■	■
Double door lock	■	■	■
AUDIO, COMMUNICATION & INFORMATION			
8" Lexus Media Display	■	■	-
10.3" multimedia display	□	□	■
8-speaker Pioneer® audio system	■	■	-
10-speaker Pioneer® audio system	□	□	■
14-speaker Mark Levinson® Premium Surround system	-	□	□
2 USB ports and AUX socket	■	■	■
Active Sound Control (ASC) ¹	-	○/■	-
Analogue clock with GPS function	■	■	■
Antenna, shark fin design	■	■	■
Bluetooth® mobile phone and audio connectivity	■	■	■
Head-Up Display (HUD)	-	○	○
Lexus Premium Navigation	○	○	■
Panoramic View Monitor	-	□	□
Parking assist monitor with on-screen guides	○	■	■
Steering wheel mounted controls - audio / display / phone / voice	■	■	■
Steering wheel mounted controls - audio / display / phone / voice / DRCC / LDA	□	■	■
Touch Pad operation for central display	■	■	■
Tuner with DAB technology ²	○	○	■
Wireless charger	○	○	○

* Only available on NX 300h FWD model.

¹ For the NX F SPORT grade, Active Sound Control is standard on NX 300h and available as an option on NX 300.² For the NX Eco grade, this option can only be ordered in combination with the Lexus Media Display pack.

INTERIOR COMFORT & CONVENIENCE	ECO*	COMFORT	Sport	BUSINESS
3-spoke, leather trimmed steering wheel with paddle shift controls	■	■	■	■
3-spoke, perforated leather trimmed steering wheel with paddle shift controls	-	-	-	-
Card key	-	-	-	-
Drilled aluminium pedals	-	-	-	-
Electrically operated windows, front and rear	■	■	■	■
Electronic climate control, 2-zone with S-Flow technology	■	■	■	■
Front centre armrest with storage box and 2 cup holders	■	■	■	■
Front seats, 6-way manually adjustable	■	■	■	■
Front seats, 8-way electrically adjustable	-	-	-	-
Front seat lumbar support, electrically adjustable, 2-way (driver)	-	-	-	-
Front seats, F SPORT design	-	-	-	-
Glass sunroof, electric tilt/slide	-	○	○	○
Heated and ventilated front seats	-	-	-	-
Heated front seats	-	○	□	■
Heated rear seats	-	-	-	-
Heated steering wheel	-	○	○	○
Illuminated entry system	■	■	■	■
Inlays, Bamboo	-	-	-	-
Inlays, Black Shimamoku	-	-	-	-
Inlays, Dark Mesh Metal	-	-	-	-
Inlays, Naguri-Style Aluminium	-	-	-	-
Inlays, Piano Black	■	■	-	-
Inlays, Silver	-	○/□	■	■
Leather trimmed gearshift knob	■	■	■	■
Luggage holding belt	■	■	■	■
Memory function for driver's seat	-	-	-	-
Panoramic sunroof ¹	-	-	□	□
Perforated leather trimmed gearshift knob	-	-	-	-
Rear centre armrest with storage space and 2 cup holders	■	■	■	■
Rear seat bench, 60:40 split-folding	■	■	■	■
Rear seat bench, 60:40 split-folding, electric operation	-	-	-	-
Rear-view mirror, manual dimming adjustment	■	-	-	-
Rear-view mirror, electro chromatic (auto-dimming)	○	■	■	■
Scuff plates, standard design	■	■	■	■
Scuff plates, F SPORT design	-	-	-	-
Scuff plates, upgraded design	-	-	-	-
Smart entry system	-	○	○	■
Steering column, manually multi-adjustable	■	■	■	■
Steering column, electrically multi-adjustable	-	-	-	-
Tyre repair kit	■	■	■	■
Temporary spare wheel	○	○	○	○
Upholstery, Fabric	■	■	■	-
Upholstery, Tahara trim	-	□	□	■
Upholstery, F SPORT leather	-	-	-	-
Upholstery, leather	-	-	-	-
Wireless door lock	■	■	■	■

- Available as standard.
- Available as an option.
- Available as part of a pack.
- Not available.

INTERIOR COMFORT & CONVENIENCE	EXECUTIVE	F SPORT	LUXURY
3-spoke, leather trimmed steering wheel with paddle shift controls	■	–	■
3-spoke, perforated leather trimmed steering wheel with paddle shift controls	–	■	–
Card key	–	–	■
Drilled aluminium pedals	–	■	–
Electrically operated windows, front and rear	■	■	■
Electronic climate control, 2-zone with S-Flow technology	■	■	■
Front centre armrest with storage box and 2 cup holders	■	■	■
Front seats, 6-way manually adjustable	–	–	–
Front seats, 8-way electrically adjustable	■	■	■
Front seat lumbar support, electrically adjustable, 2-way (driver)	–	■	■
Front seats, F SPORT design	–	■	–
Glass sunroof, electric tilt/slide	○	○	○
Heated and ventilated front seats	–	□	■
Heated front seats	■	■	■
Heated rear seats	–	□	■
Heated steering wheel	○	○	○
Illuminated entry system	■	■	■
Inlays, Bamboo	–	–	■
Inlays, Black Shimamoku	–	–	■
Inlays, Dark Mesh Metal	–	■	–
Inlays, Naguri-Style Aluminium	–	○	–
Inlays, Piano Black	–	–	–
Inlays, Silver	■	–	–
Leather trimmed gearshift knob	■	–	■
Luggage holding belt	■	■	■
Memory function for driver's seat	–	□	■
Panoramic sunroof ¹	□	□	□
Perforated leather trimmed gearshift knob	–	■	–
Rear centre armrest with storage space and 2 cup holders	■	■	■
Rear seat bench, 60:40 split-folding	■	■	■
Rear seat bench, 60:40 split-folding, electric operation	–	–	○
Rear-view mirror, manual dimming adjustment	–	–	–
Rear-view mirror, electro chromatic (auto-dimming)	■	■	■
Scuff plates, standard design	–	–	–
Scuff plates, F SPORT design	–	■	–
Scuff plates, upgraded design	■	–	■
Smart entry system	■	■	■
Steering column, manually multi-adjustable	■	–	–
Steering column, electrically multi-adjustable	–	■	■
Tyre repair kit	■	■	■
Temporary spare wheel	○	○	○
Upholstery, Fabric	–	–	–
Upholstery, Tahara trim	–	–	–
Upholstery, F SPORT leather	–	■	–
Upholstery, leather	■	–	■
Wireless door lock	■	■	■

* Only available on NX 300h FWD model.

¹ If panoramic sunroof is specified, the otherwise standard fitment roof rails are not supplied due to technical reasons.

EQUIPMENT | PACKS

PACKS	ECO*	COMFORT	Sport	BUSINESS
Sports driving	-	-	-	-
Adaptive Variable Suspension (AVS)	-	-	-	-
Drive Mode Select (Eco - Normal / Custom - Sport S / Sport S+)	-	-	-	-
Lexus Safety System +	□	□	□	□
Pre-Collision System (PCS)	□	□	□	□
Lane Departure Alert (LDA) with Sway Warning function	□	□	□	□
Lane Tracing Assist (LTA)	-	-	-	-
Road Sign Assist (RSA)	□	□	□	□
Dynamic Radar Cruise Control (DRCC), all-speed	□	□	□	□
Automatic High Beam (AHB)	□	□	□	□
Adaptive High-beam System (AHS)	-	-	-	-
Steering wheel mounted controls - audio / display / phone / voice / DRCC / LDA	□	□	□	□
Lexus Media Display	□	■	■	■
8" Lexus Media Display	□	■	■	■
8-speaker Pioneer® audio system	□	■	■	■
Analogue clock with GPS function	□	■	■	■
Bluetooth® mobile phone and audio connectivity	□	■	■	■
2 USB ports and AUX socket	□	■	■	■
Rain sensing windscreen wipers	□	■	■	■
Lexus Media Display with DAB tuner	□	-	-	-
Contents of the Lexus Media Display pack with	□	■	■	■
Tuner with DAB technology	□	○	○	○
Lexus Premium Navigation	-	□	□	□
Lexus Premium Navigation	-	○	○	○
10.3" multimedia display	-	□	□	□
10-speaker Pioneer® audio system	-	□	□	□
Tuner with DAB technology	□	○	○	○
Lexus Premium Navigation with Mark Levinson® upgrade	-	-	-	-
Contents of Lexus Premium Navigation pack with	-	□	□	□
14-speaker Mark Levinson® Premium Surround system	-	-	-	-
Lexus Premium Navigation with Mark Levinson® upgrade and Panoramic View Monitor	-	-	-	-
Contents of Lexus Premium Navigation pack with	-	□	□	□
14-speaker Mark Levinson® Premium Surround system	-	-	-	-
Panoramic View Monitor	-	-	-	-
Tahara trim plus	-	□	□	-
Tahara upholstery	-	□	□	■
Heated front seats	-	○	□	■
Inlays, Silver	-	○	■	■
FSPORT leather plus	-	-	-	-
Memory function for driver's seat	-	-	-	-
Heated and ventilated front seats	-	-	-	-
Heated rear seats	-	-	-	-

- Standard on specific grade(s).
- Available as an option.
- Available as (part of) a pack.
- Not available.

PACKS	EXECUTIVE	F SPORT	LUXURY
Sports driving	–	□	□
Adaptive Variable Suspension (AVS)	–	□	□
Drive Mode Select (Eco - Normal / Custom - Sport S / Sport S+)	–	□	□
Lexus Safety System +	□	■	■
Pre-Collision System (PCS)	□	■	■
Lane Departure Alert (LDA) with Sway Warning function	□	■	■
Lane Tracing Assist (LTA)	–	■	■
Road Sign Assist (RSA)	□	■	■
Dynamic Radar Cruise Control (DRCC), all-speed	□	■	■
Automatic High Beam (AHB)	□	–	–
Adaptive High-beam System (AHS)	–	■	■
Steering wheel mounted controls - audio / display / phone / voice / DRCC / LDA	□	■	■
Lexus Media Display	■	■	–
8" Lexus Media Display	■	■	–
8-speaker Pioneer® audio system	■	■	–
Analogue clock with GPS function	■	■	■
Bluetooth® mobile phone and audio connectivity	■	■	■
2 USB ports and AUX socket	■	■	■
Rain sensing windscreen wipers	■	■	■
Lexus Media Display with DAB tuner	–	–	–
Contents of the Lexus Media Display pack with Tuner with DAB technology	■ ○	■ ○	– ■
Lexus Premium Navigation	□	□	■
Lexus Premium Navigation	○	○	■
10.3" multimedia display	□	□	■
10-speaker Pioneer® audio system	□	□	■
Tuner with DAB technology	○	○	■
Lexus Premium Navigation with Mark Levinson® upgrade	–	□	□
Contents of Lexus Premium Navigation pack with 14-speaker Mark Levinson® Premium Surround system	□ –	□ □	■ □
Lexus Premium Navigation with Mark Levinson® upgrade and Panoramic View Monitor	–	□	□
Contents of Lexus Premium Navigation pack with 14-speaker Mark Levinson® Premium Surround system Panoramic View Monitor	□ – –	□ □ □	■ □ □
Tahara trim plus	–	–	–
Tahara upholstery	–	–	–
Heated front seats	■	■	■
Inlays, Silver	■	–	–
FSPORT leather plus	–	□	■
Memory function for driver's seat	–	□	■
Heated and ventilated front seats	–	□	■
Heated rear seats	–	□	■

* Only available on NX 300h FWD models.

TECHNICAL DATA

ENGINE	NX 300 FWD (AWD)	NX 300h FWD (AWD)
Capacity (cm ³)	1998	2494
Cylinders / Valves	L4/ 16	L4/ 16
Maximum power (DIN hp @ rpm)	238 @ 5200 - 5600	155 @ 5700
Maximum power (kW @ rpm)	175 @ 5200 - 5600	114 @ 5700
Maximum torque (Nm @ rpm)	350 @ 1650 - 4000	210 @ 4200 - 4400
ELECTRIC MOTOR(S)		
Type	–	AC synchronous, permanent magnet
Maximum power (DIN hp) front / rear	–	143 / - (143 / 68)
Maximum power (kW) front / rear	–	105 / - (105 / 50)
Maximum torque (Nm) front / rear	–	270 / - (270 / 139)
TRANSMISSION		
Type	6-speed Automatic	Electronic-Continuously Variable Transmission
Drive	Front-Wheel Drive (All-Wheel Drive)	Front-Wheel Drive (All-Wheel Drive)
TOTAL SYSTEM OUTPUT		
Total power (DIN hp)	238	197
Total power (kW)	175	145
PERFORMANCE		
Maximum speed (km/h)	200	180
Acceleration 0-100 km/h (s)	7.3 (7.1)	9.2
FUEL CONSUMPTION* (l/100km)		
Combined	from 9.3 to 9.5 (from 9.6 to 10.2)	from 7.0 to 7.5 (from 7.2 to 7.7)
CO₂ EMISSIONS* (g/km)		
Combined	from 211 to 217 (from 218 to 230)	from 159 to 170 (from 162 to 175)
EMISSION STANDARD		
Euro Class	Euro 6d	Euro 6d
WEIGHTS** (kg)		
Gross vehicle	2295 (2350)	2245 / 2330 (2395)
Kerb weight (min. - max.)	1680 - 1805 (1735 - 1860)	1715 - 1755 / 1720 - 1840 (1785 - 1905)
CAPACITIES***		
Luggage volume - rear seats upright, loaded to luggage cover (l)	500 / 580	475 / 555
Luggage volume - rear seats folded down, loaded to the roof (l)	1545 / 1625	1520 / 1600
Fuel tank capacity (l)	60	56
Towing capacity max. unbraked**** (kg)	750	0 / 650 (750)
Towing capacity max. braked**** (kg)	1500	0 / 650 (1500)

* The fuel consumption and CO₂ values are measured in a controlled environment on a representative production model, in accordance with the requirements of the new WLTP European Regulation EC 2017/1151 and its applicable amendments. For each individual vehicle configuration, the final fuel consumption and CO₂ values may be calculated based on the ordered optional equipment. The fuel consumption and CO₂ values of your vehicle may vary from those measured or calculated values, as driving behaviour as well as other factors (such as road conditions, traffic, vehicle condition, tyre pressure, load, number of passengers, etc.) have an influence on a car's fuel consumption and CO₂ emissions. For more information regarding the new WLTP test method, please visit: www.lexus.eu/wltp#nedc

** For the NX 300h FWD, 1st figure is for the Eco grade. 2nd figure is for all other grades.

*** Luggage volume is calculated as per the VDA method. 1st figure is for the vehicle specified with a temporary spare wheel. 2nd figure is for the vehicle specified with a tyre repair kit. All figures quoted include the under floor storage area in the luggage compartment. For the NX 300h FWD, 1st towing capacity figure is for the Eco grade specified without towing capacity to achieve a lower CO₂ and fuel consumption. 2nd figure is for all other grades.

**** For the NX 300h FWD, 1st towing capacity figure is for the Eco grade specified without towing capacity to achieve a lower CO₂ and fuel consumption. 2nd figure is for all other grades. For models equipped with optional tailgate kick-open function no towing capability is provided.

Please note: further Technical Data, including any updates, can be found at www.lexus.eu

TECHNICAL DATA

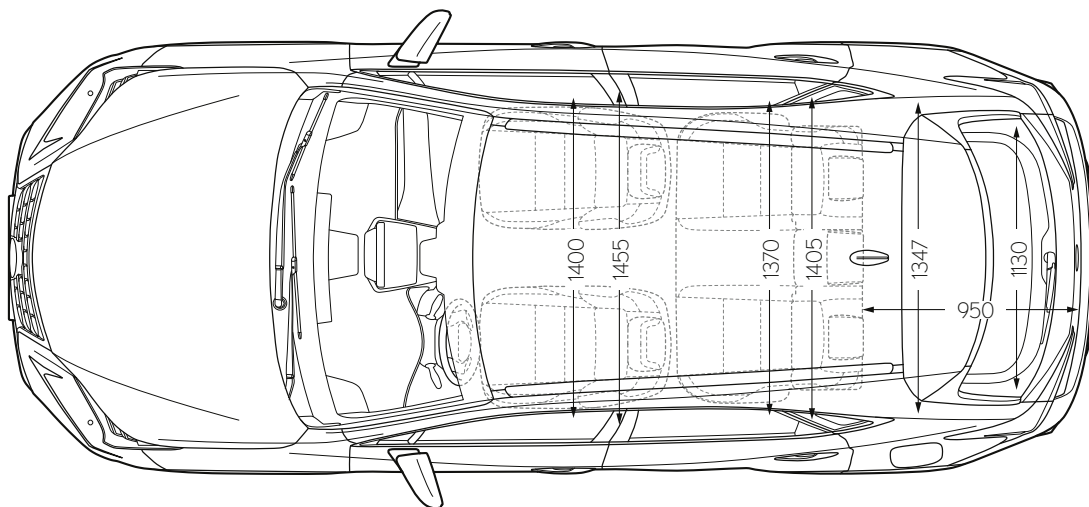
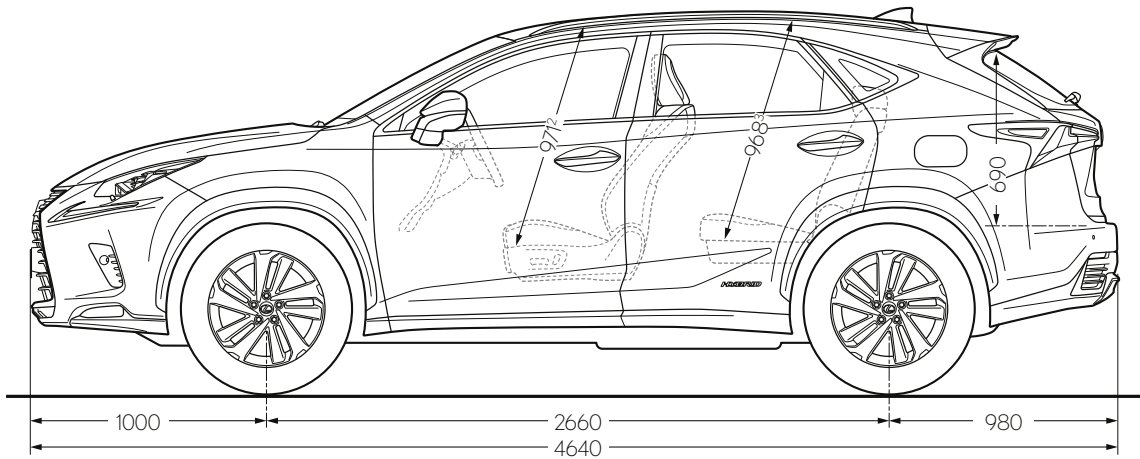
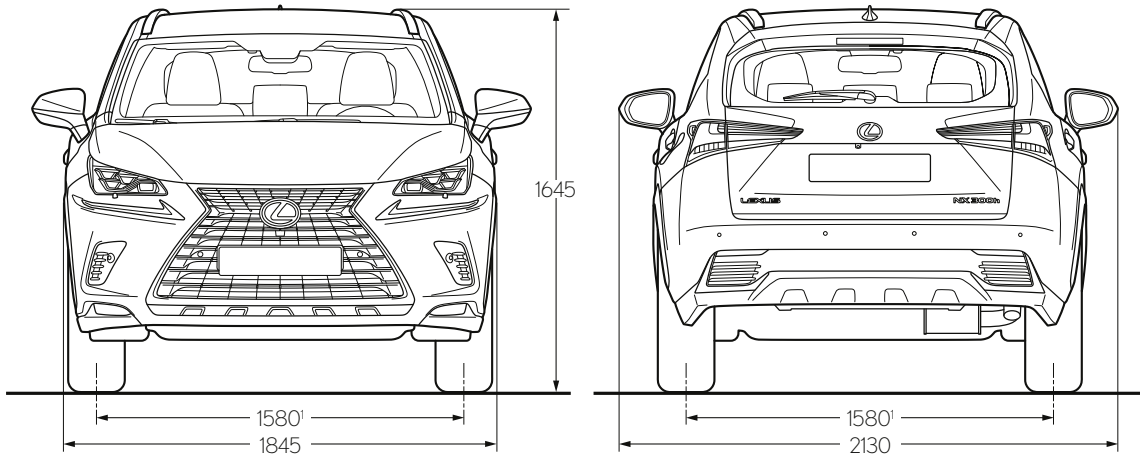

¹When specified with 235/55 R18 tyres, both the front and rear track figures are 1570.

²When specified with a sunroof the front headroom figure is 950 and when specified with a panoramic roof it is 976.

³When specified with a sunroof the rear headroom figure is 967 and when specified with a panoramic roof it is 938.

Please note: the dimensions illustrated / noted are measured in millimetres.



Throughout your vehicle's life, we'll endeavour to ensure an amazing ownership experience, offering unequalled service and seamless maintenance work, all orchestrated to provide complete satisfaction and total peace of mind. When you visit our showrooms, we strive to anticipate your every need and make available the finest facilities for you to enjoy in a warm and relaxed atmosphere. In the modern Lexus lounge, you can catch up on news, browse the Internet, or enjoy refreshments. While you relax, Lexus technicians will work with precision and efficiency to get you back on the road with minimum interruption to your day.





WE AIM TO TREAT EVERY CUSTOMER AS IF THEY WERE A GUEST IN OUR OWN HOME

Ever since we launched the first Lexus, we have always gone 'the extra mile' for our customers. Evidenced by countless awards over the last 30 years, we aim to treat every customer as if they were a guest in our home. But which other factors contribute to our peerless level of customer service? The answer lies in our Japanese heritage and one word: 'Omotenashi'

Omotenashi translates from the Japanese as 'hospitality and polite service'. However, Omotenashi is much more than excellence of service; it is an ancient Japanese concept that describes one's ability to anticipate the needs of another, even before they arise.

Omotenashi is a way of life and thinking for every single Lexus employee. Importantly, it also influences how we design and engineer cars like the NX. This is Omotenashi in physical form.

More about the NX:
lexus.eu/NX
youtube.com/LexusEurope
twitter.com/Lexus_EU

© 2019 Lexus Europe* reserves the right to alter any details of specifications and equipment without notice. Details of specifications and equipment are also subject to change to suit local conditions and requirements. Please enquire at your local Lexus Authorised Retailer of any such changes that might be required for your area.

Note: vehicles pictured and specifications detailed in this brochure may vary from models and equipment available in your area. Vehicle body colour might differ slightly from the printed photos in this brochure.

For further information please visit our website: www.lexus.eu

Taking care of the environment is a priority for Lexus. We take many measures to ensure that during the lifecycles of our vehicles - from design, production, distribution, sales and service to end-of-life - their environmental impact is minimised. Your retailer will be happy to provide more information on end-of-life vehicle requirements.

* Lexus Europe is a division of Toyota Motor Europe NV/SA.

Printed in Europe, June 2019

